

## SUPPORT WITH CYLINDRICAL SHAFT FOR PUMP GR.3

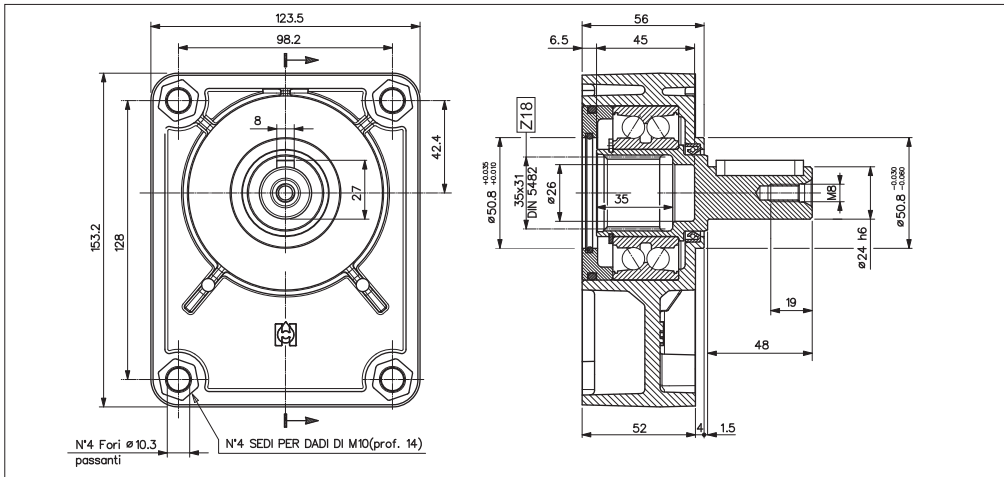

The SU/3-C, is suitable for driving Gr.3 hydraulic pumps and motors, with belts, chain or other transmission, in which heavy combined loads take place (axial and radial). The pump/motor Gr. 3, is directly flanged and connected by splined coupling (coupling to be ordered separately).

### MAXIMUM LOAD ON THE SHAFT

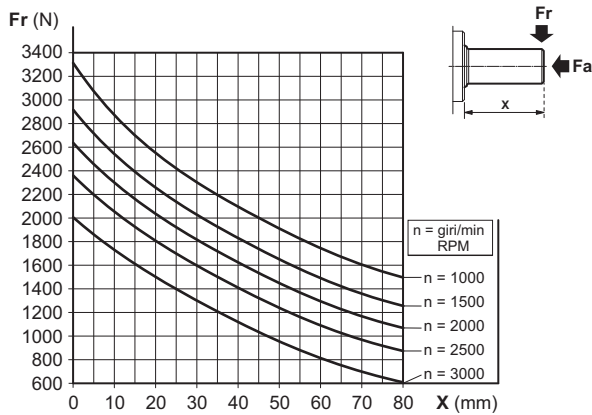

### FEATURES

Minimum radial load (*)	Fr = 277 N
Radial load (*)	See graphic
Axial load (*)	Fa ≤ Fr • 0,8
Max. revolutions per minute	3500 RPM
Life (*)	3500 hours
Max. working temperature	70 °C
Grease quantity	19 ÷ 23.5 gr
Type of grease	DIN 51818 NLGI classe 2

(\*) Nominal values calculated according to ISO 281. For more information, contact our technical department.

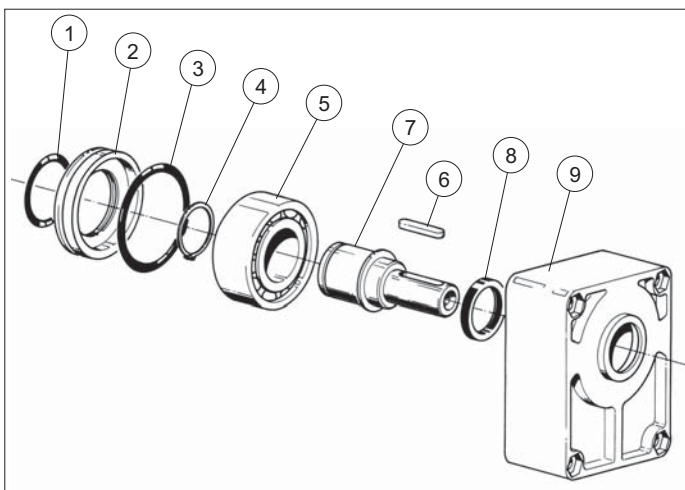

### SPARE PARTS

Ref.	Code	Description	Q.ty
1	Q25830122	O-Ring 50.47x2.62	1
2	39025900	Cover	1
3	Q25830232	O-Ring 73.03x3.53	1
4	Q27150400	Snap ring E40	1
5	44005400	Bearing 3208 40x80x30.2	1
6	Q27470305	Woodruff A8x7x40	1
7	34215500	Cylindrical shaft	1
8	44104100	Shaft seal 45x35x7	1
9	39043700	Body	1

### ORDERING CODE



## SUPPORT WITH TAPERED SHAFT FOR PUMP GR.3

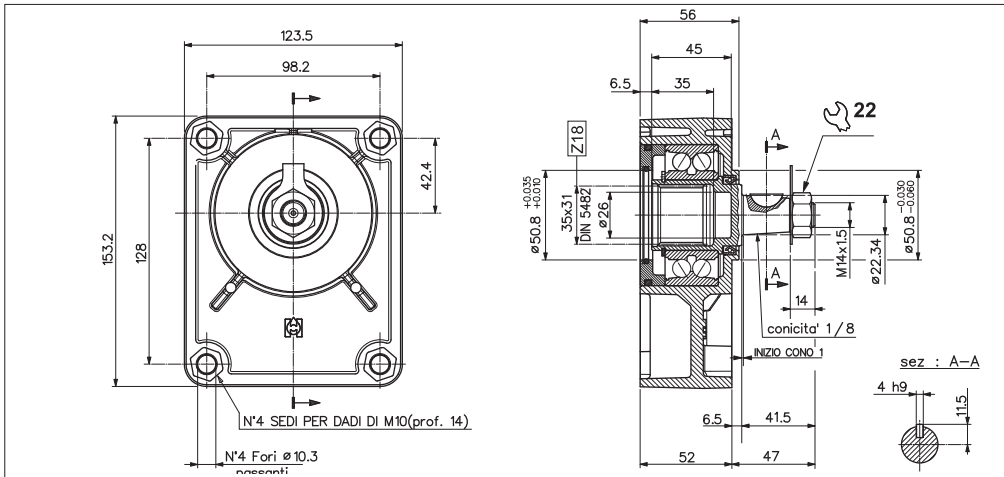

The SU/3-D (tapered shaft), is suitable for driving Gr. 3 hydraulic pumps and motors, with belts, chain or other transmission, in which heavy combined loads take place (axial and radial).

The pump/motor Gr. 3, is directly flanged and connected by splined coupling (coupling to be ordered separately).

### MAXIMUM LOAD ON THE SHAFT

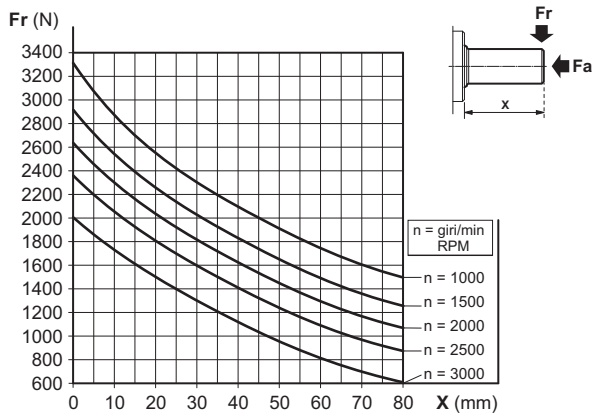

### FEATURES

Minimum radial load (*)	Fr = 277 N
Radial load (*)	See graphic
Axial load (*)	Fa ≤ Fr • 0,8
Max. revolutions per minute	3500 RPM
Life (*)	3500 hours
Max. working temperature	70 °C
Grease quantity	19 ÷ 23.5 gr
Type of grease	DIN 51818 NLGI classe 2

(\*) Nominal values calculated according to ISO 281. For more information, contact our technical department.

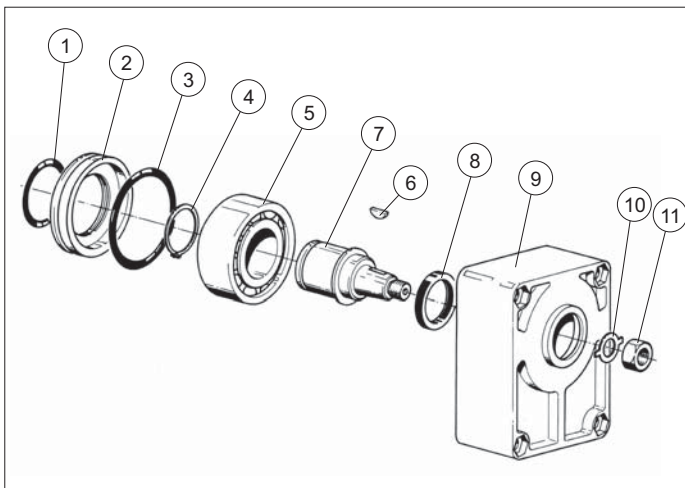

### SPARE PARTS

Ref.	Code	Description	Q.ty
1	Q25830122	O-Ring 50.47x2.62	1
2	39025900	Cover	1
3	Q25830232	O-Ring 73.03x3.53	1
4	Q27150400	Snap ring E40	1
5	44005400	Bearing 3208 40x80x30.2	1
6	Q27500075	Woodruff 4x7.5	1
7	34215600	Tapered shaft	1
8	44104100	Shaft seal 45x35x7	1
9	39043700	Body	1
10	42101500	Washer	1
11	Q26514141	Nut M14x11x1.5	1

### ORDERING CODE

