



Tabella dimensionali

Dimension Pages

Abmessungsseiten

Foro di centraggio filettato secondo DIN 332 foglio 2 / Tapped center hole to DIN 332, sheet 2 / Zentrierung mit gewinde DIN 332, Blatt 2

KV373.00

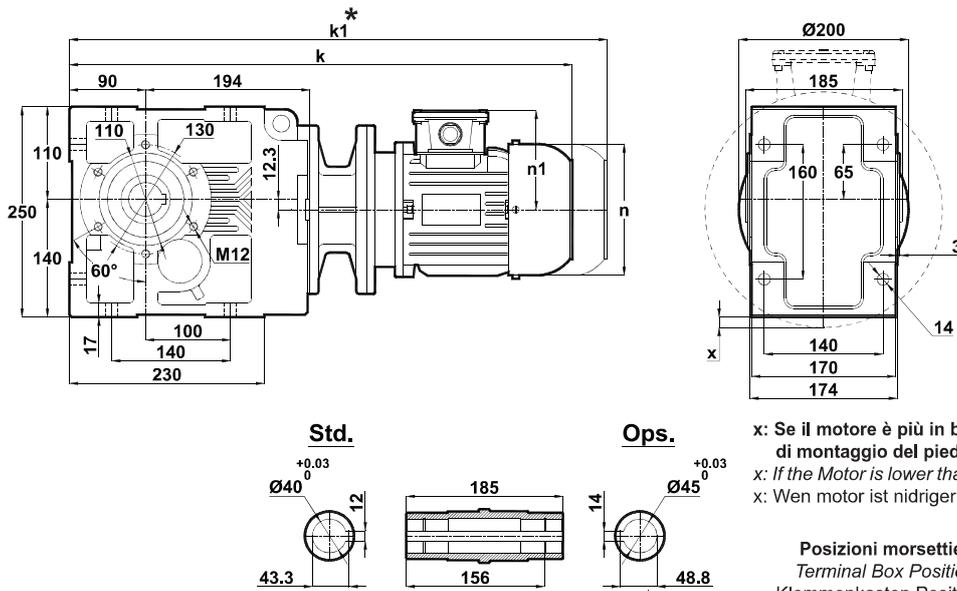

x: Se il motore è più in basso rispetto alla piastra di montaggio del piede
 x: If the Motor is lower than the foot mounting plane
 x: Wenn motor ist niedriger den die Anschlußplatte

Posizioni morsetteria
 Terminal Box Positions
 Klemmenkasten Positionen

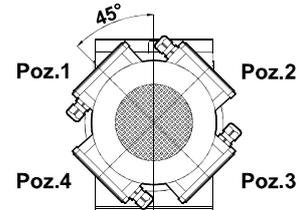

71-80-90-100-112-132
 Tipo / Type / Typ

	71/B5	80/B5	90S/B5	90L/B5	100L/B5	112M/B5	132S/B5	132M/B5
k	570	590	610	635	684	704	768	806
k1	690	710	735	760	819	839	913	951
n	138	156	176	176	194	218	258	258
n1	110	118	126	126	135	146	168	168
x	-	-	-	-	-	-	1,3	1,3

KV373.01

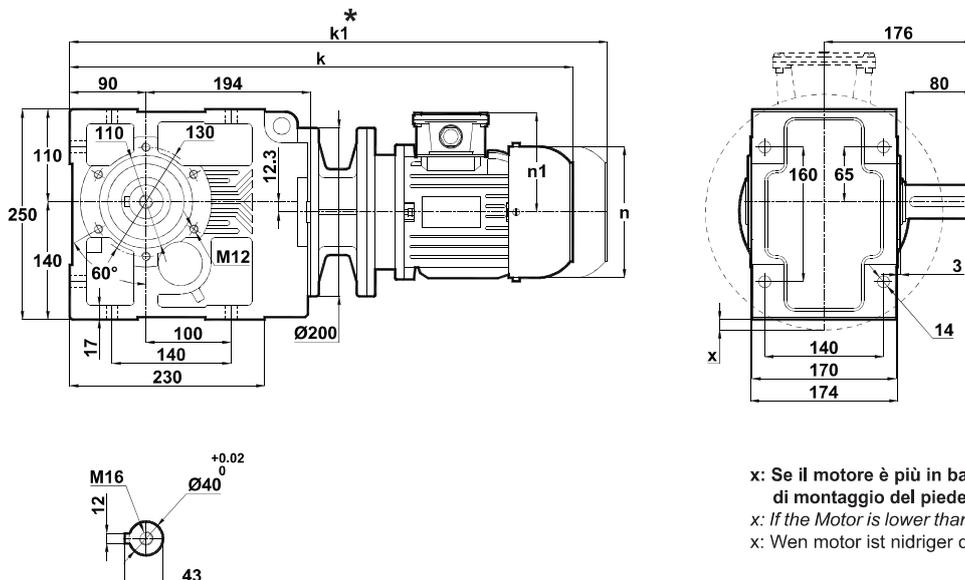

x: Se il motore è più in basso rispetto alla piastra di montaggio del piede
 x: If the Motor is lower than the foot mounting plane
 x: Wenn motor ist niedriger den die Anschlußplatte

La misura "k1" è per motori dotati di freno. I riduttori completi di motori elettrici tipo 63 e 71 non hanno la ventola di raffreddamento, che invece hanno gli altri tipi.
 Dimension "k1" is for motors with brake. Gearboxes with 63 and 71 type electrical motors are not fan cooled, other types are fan cooled.
 Maße "k1" ist für Bremsenmotoren. Getrieben mit 63 und 71 typ Motoren sind ohne Kühlung, andere Typen sind mit Ventilator gekühlt.

La misura "k1" è per motori dotati di freno.
 Dimension "k1" is for motors with brake.
 Maße "k1" ist für Bremsenmotoren.

	71/B5	80/B5	90S/B5	90L/B5	100L/B5	112M/B5	132S/B5	132M/B5
k	570	590	610	635	684	704	768	806
k1	690	710	735	760	819	839	913	951
n	138	156	176	176	194	218	258	258
n1	110	118	126	126	135	146	168	168
x	-	-	-	-	-	-	1,3	1,3



Tabelle dimensionali

Dimension Pages

Abmessungsseiten

Foro di centraggio filettato secondo DIN 332 foglio 2 / Tapped center hole to DIN 332, sheet 2 / Zentrierung mit gewinde DIN 332, Blatt 2

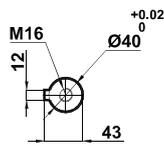
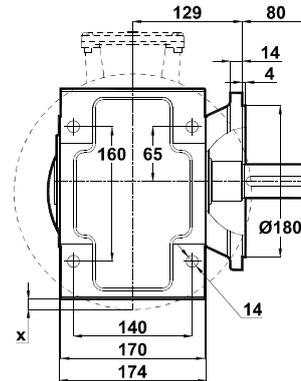
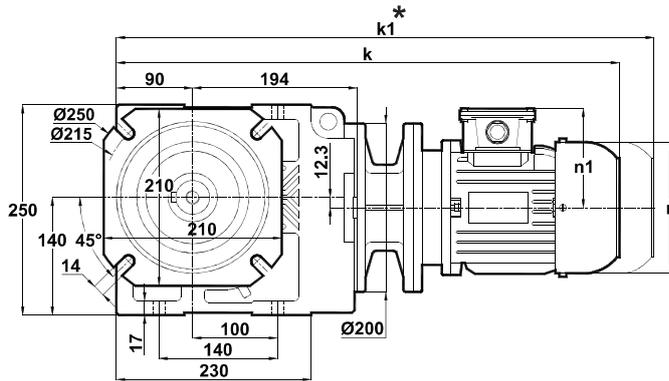

x: Se il motore è più in basso rispetto alla piastra di montaggio del piede

x: If the Motor is lower than the foot mounting plane

x: Wenn motor ist niedriger den die Anschlußplatte

Posizioni morsetti
Terminal Box Positions
Klemmenkasten Positionen

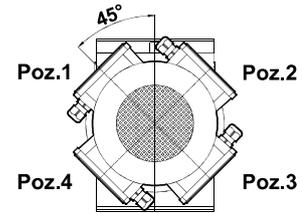

71-80-90-100-112-132
Tipo / Type / Typ

	71/B5	80/B5	90S/B5	90L/B5	100L/B5	112M/B5	132S/B5	132M/B5
k	570	590	610	635	684	704	768	806
k1	690	710	735	760	819	839	913	951
n	138	156	176	176	194	218	258	258
n1	110	118	126	126	135	146	168	168
x	-	-	-	-	-	-	1,3	1,3

KV373.03

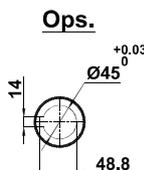
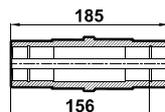
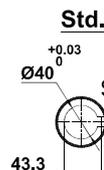
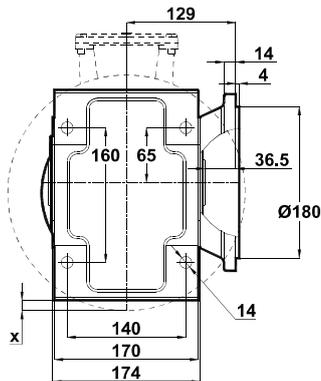
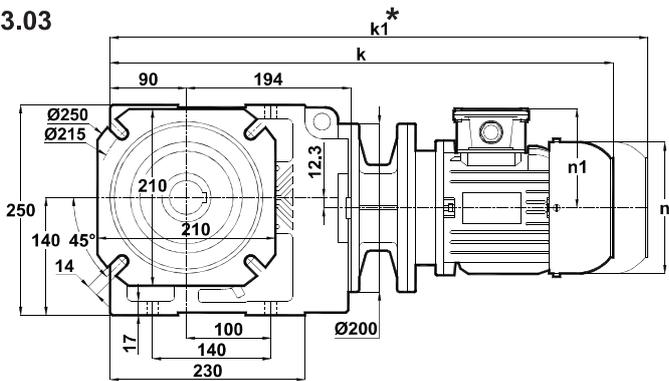

x: Se il motore è più in basso rispetto alla piastra di montaggio del piede

x: If the Motor is lower than the foot mounting plane

x: Wenn motor ist niedriger den die Anschlußplatte

	71/B5	80/B5	90S/B5	90L/B5	100L/B5	112M/B5	132S/B5	132M/B5
k	570	590	610	635	684	704	768	806
k1	690	710	735	760	819	839	913	951
n	138	156	176	176	194	218	258	258
n1	110	118	126	126	135	146	168	168
x	-	-	-	-	-	-	1,3	1,3

La misura "k1" è per motori dotati di freno.
Dimension "k1" is for motors with brake.
Maße "k1" ist für Bremsenmotoren.



Tabella dimensionali

Dimension Pages

Abmessungsseiten

Foro di centraggio filettato secondo DIN 332 foglio 2 / Tapped center hole to DIN 332, sheet 2 / Zentrierung mit gewinde DIN 332, Blatt 2

KV373.04
KV373.04

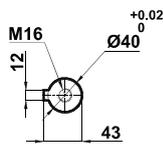
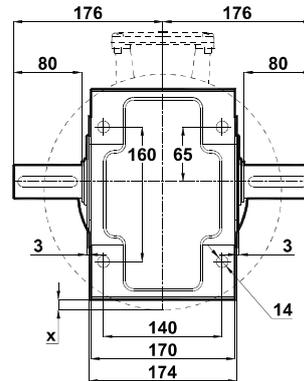
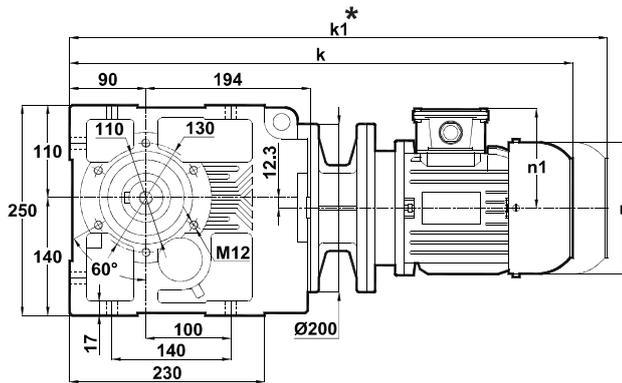

x: Se il motore è più in basso rispetto alla piastra di montaggio del piede

x: If the Motor is lower than the foot mounting plane

x: Wenn motor ist niedriger den die Anschlußplatte

Posizioni morsetteria
Terminal Box Positions
Klemmenkasten Positionen

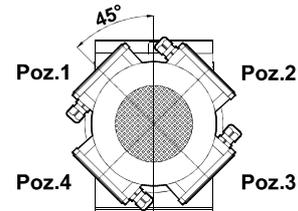

71-80-90-100-112-132
Tipo / Type / Typ

	71/B5	80/B5	90S/B5	90L/B5	100L/B5	112M/B5	132S/B5	132M/B5
k	570	590	610	635	684	704	768	806
k1	690	710	735	760	819	839	913	951
n	138	156	176	176	194	218	258	258
n1	110	118	126	126	135	146	168	168
x	-	-	-	-	-	-	1,3	1,3

KV373.05
KV373.05

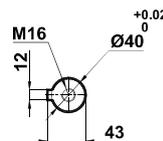
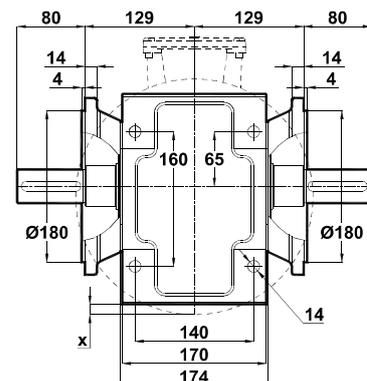
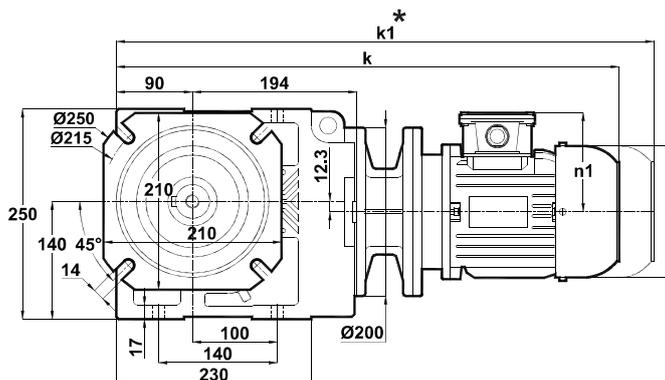

x: Se il motore è più in basso rispetto alla piastra di montaggio del piede

x: If the Motor is lower than the foot mounting plane

x: Wenn motor ist niedriger den die Anschlußplatte

	71/B5	80/B5	90S/B5	90L/B5	100L/B5	112M/B5	132S/B5	132M/B5
k	570	590	610	635	684	704	768	806
k1	690	710	735	760	819	839	913	951
n	138	156	176	176	194	218	258	258
n1	110	118	126	126	135	146	168	168
x	-	-	-	-	-	-	1,3	1,3

La misura "k1" è per motori dotati di freno. I riduttori completi di motori elettrici tipo 63 e 71 non hanno la ventola di raffreddamento, che invece hanno gli altri tipi. Dimension "k1" is for motors with brake. Gearboxes with 63 and 71 type electrical motors are not fan cooled, other types are fan cooled.

Maße "k1" ist für Bremsenmotoren. Getrieben mit 63 und 71 typ Motoren sind ohne Kühlung, andere Typen sind mit Ventilator gekühlt.

La misura "k1" è per motori dotati di freno. Dimension "k1" is for motors with brake. Maße "k1" ist für Bremsenmotoren.



Tabelle dimensionali

Dimension Pages

Abmessungsseiten

Foro di centraggio filettato secondo DIN 332 foglio 2 / Tapped center hole to DIN 332, sheet 2 / Zentrierung mit gewinde DIN 332, Blatt 2

KV373.08
KV373.08

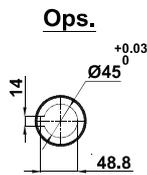
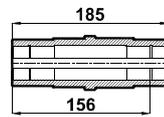
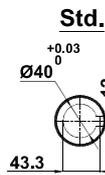
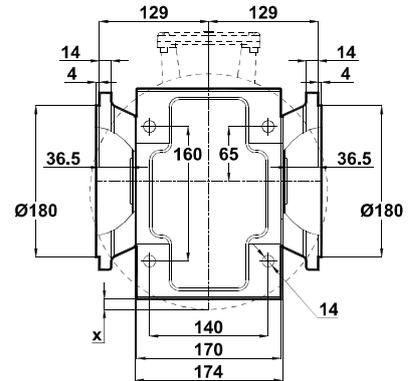
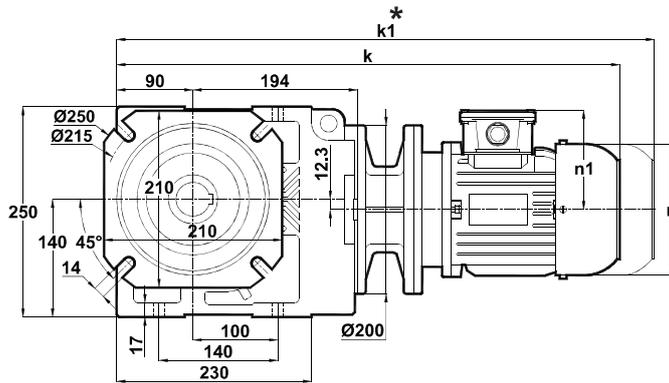

x: Se il motore è più in basso rispetto alla piastra di montaggio del piede
 x: If the Motor is lower than the foot mounting plane
 x: Wenn motor ist niedriger den die Anschlußplatte

Posizioni morsettiera
 Terminal Box Positions
 Klemmenkasten Positionen

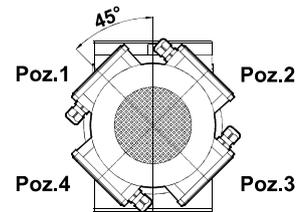

71-80-90-100-112-132
 Tipo / Type / Typ

	71/B5	80/B5	90S/B5	90L/B5	100L/B5	112M/B5	132S/B5	132M/B5
k	570	590	610	635	684	704	768	806
k1	690	710	735	760	819	839	913	951
n	138	156	176	176	194	218	258	258
n1	110	118	126	126	135	146	168	168
x	-	-	-	-	-	-	1,3	1,3

La misura "k1" è per motori dotati di freno.
 Dimension "k1" is for motors with brake.
 Maße "k1" ist für Bremsenmotoren.



Tabelle dimensionali

Dimension Pages

Abmessungsseiten

Foro di centraggio filettato secondo DIN 332 foglio 2 / Tapped center hole to DIN 332, sheet 2 / Zentrierung mit gewinde DIN 332, Blatt 2

KV374.00

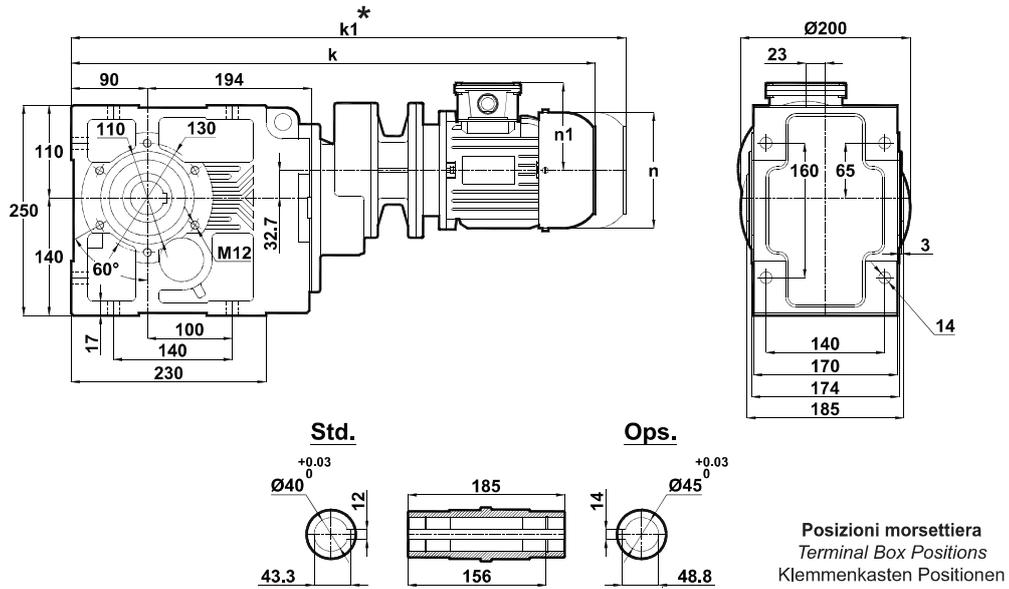

	63/B5	71/B5	80/B5
k	621	618	667
k1	-	738	787
n	116	138	156
n1	97	110	118

Posizioni morsettiere
Terminal Box Positions
Klemmenkasten Positionen

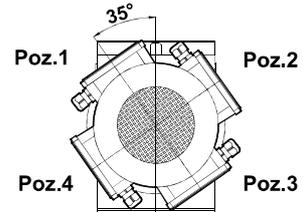

63-71-80
Tipo I Type I Typ

KV374.01

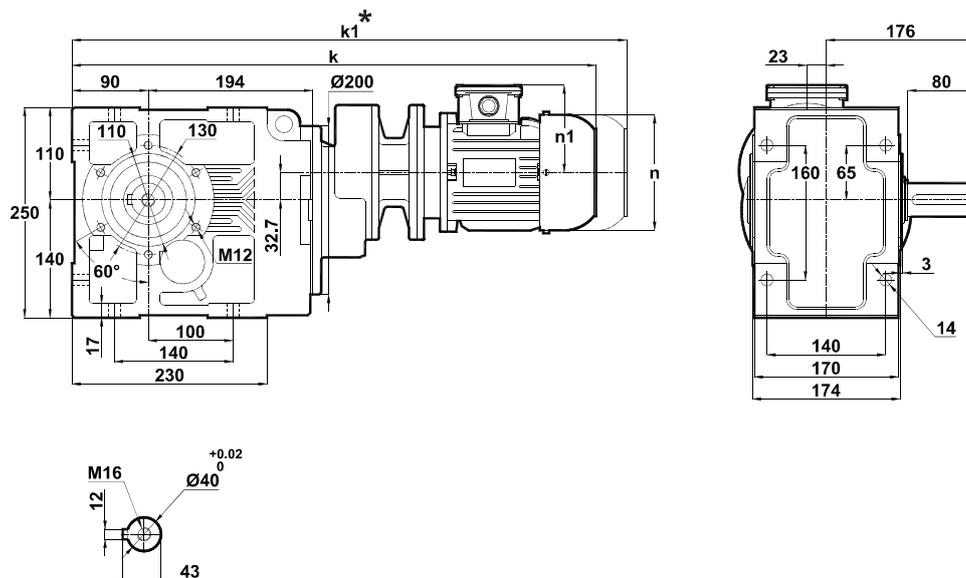

	63/B5	71/B5	80/B5
k	621	618	667
k1	-	738	787
n	116	138	156
n1	97	110	118

La misura "k1" è per motori dotati di freno. I riduttori completi di motori elettrici tipo 63 e 71 non hanno la ventola di raffreddamento, che invece hanno gli altri tipi.
Dimension "k1" is for motors with brake. Gearboxes with 63 and 71 type electrical motors are not fan cooled, other types are fan cooled.

Maße "k1" ist für Bremsenmotoren. Getrieben mit 63 und 71 typ Motoren sind ohne Kühlung, andere Typen sind mit Ventilator gekühlt.

La misura "k1" è per motori dotati di freno.
Dimension "k1" is for motors with brake.
Maße "k1" ist für Bremsenmotoren.



Tabelle dimensionali

Dimension Pages

Abmessungsseiten

Foro di centraggio filettato secondo DIN 332 foglio 2 / Tapped center hole to DIN 332, sheet 2 / Zentrierung mit gewinde DIN 332, Blatt 2

KV374.02

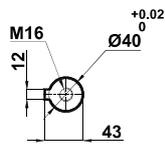
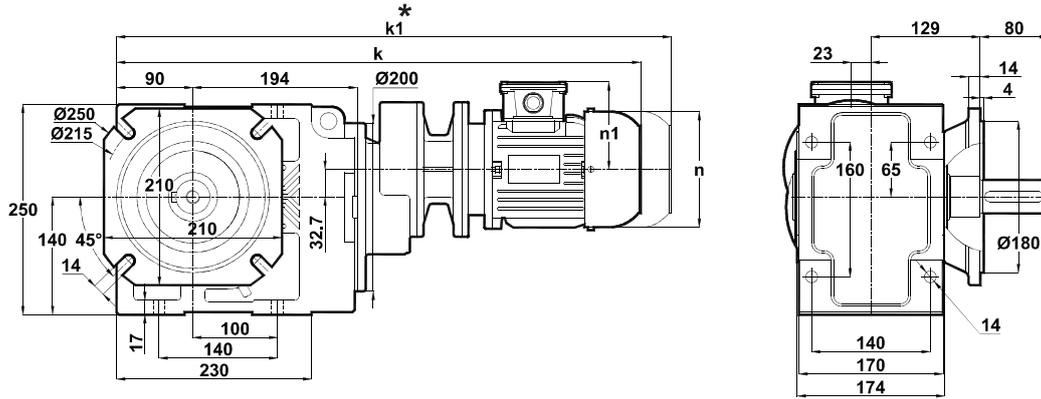

	63/B5	71/B5	80/B5
k	621	618	667
k1	-	738	787
n	116	138	156
n1	97	110	118

Posizioni morsettiera
Terminal Box Positions
Klemmenkasten Positionen

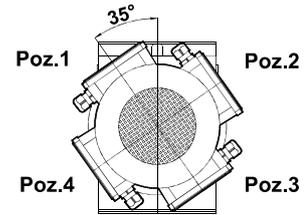

63-71-80
Tipo / Type / Typ

KV374.03

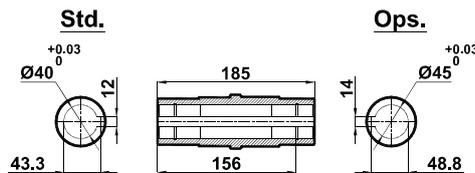
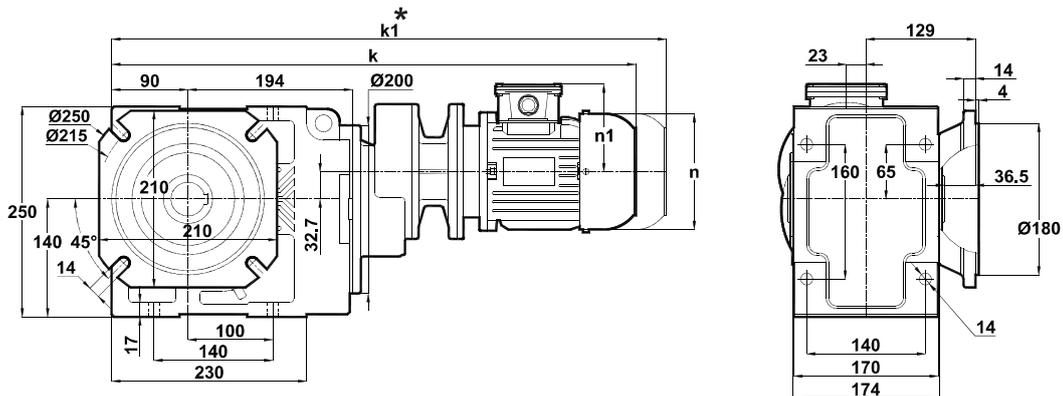

	63/B5	71/B5	80/B5
k	621	618	667
k1	-	738	787
n	116	138	156
n1	97	110	118

La misura "k1" è per motori dotati di freno.
Dimension "k1" is for motors with brake.
Maße "k1" ist für Bremsenmotoren.



Tabella dimensionali

Dimension Pages

Abmessungsseiten

Foro di centraggio filettato secondo DIN 332 foglio 2 / Tapped center hole to DIN 332, sheet 2 / Zentrierung mit gewinde DIN 332, Blatt 2

KV374.04

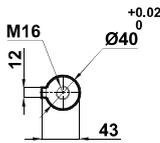
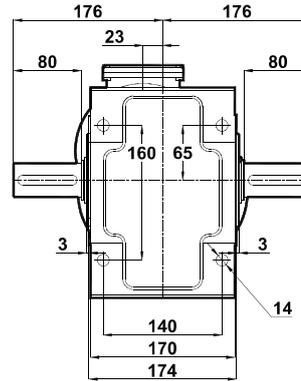
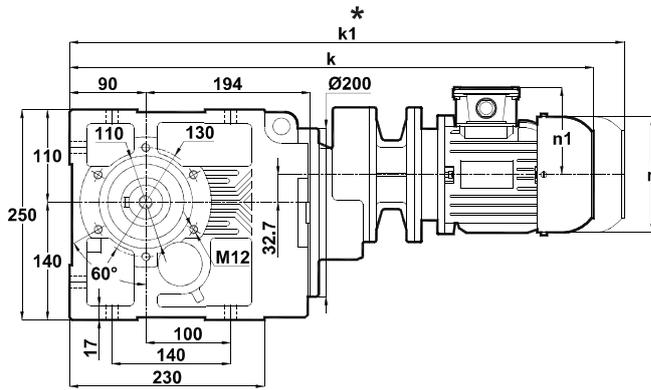

Posizioni morsetteria
Terminal Box Positions
Klemmenkasten Positionen

	63/B5	71/B5	80/B5
k	621	618	667
k1	-	738	787
n	116	138	156
n1	97	110	118

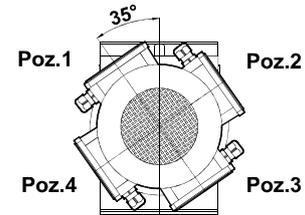

63-71-80
Tipo / Type / Typ

KV374.05

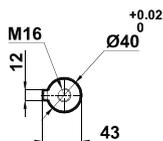
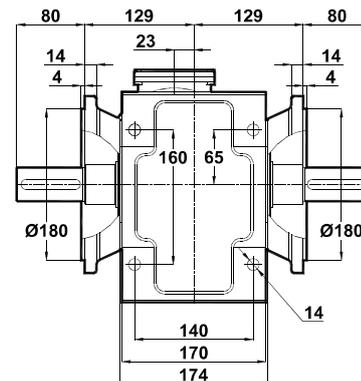
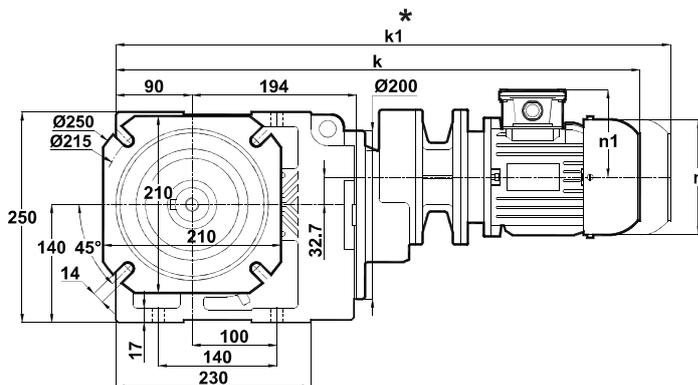

	63/B5	71/B5	80/B5
k	621	618	667
k1	-	738	787
n	116	138	156
n1	97	110	118

La misura "k1" è per motori dotati di freno. I riduttori completi di motori elettrici tipo 63 e 71 non hanno la ventola di raffreddamento, che invece hanno gli altri tipi.
Dimension "k1" is for motors with brake. Gearboxes with 63 and 71 type electrical motors are not fan cooled, other types are fan cooled.
Maße "k1" ist für Bremsenmotoren. Getrieben mit 63 und 71 typ Motoren sind ohne Kühlung, andere Typen sind mit Ventilator gekühlt.

La misura "k1" è per motori dotati di freno.
Dimension "k1" is for motors with brake.
Maße "k1" ist für Bremsenmotoren.



Tabelle dimensionali

Dimension Pages

Abmessungsseiten

Foro di centraggio filettato secondo DIN 332 foglio 2 / Tapped center hole to DIN 332, sheet 2 / Zentrierung mit gewinde DIN 332, Blatt 2

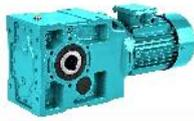
KV374.08

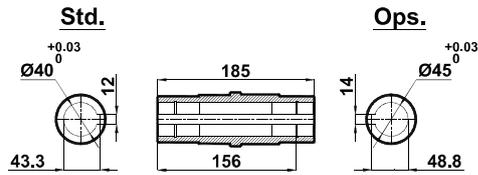
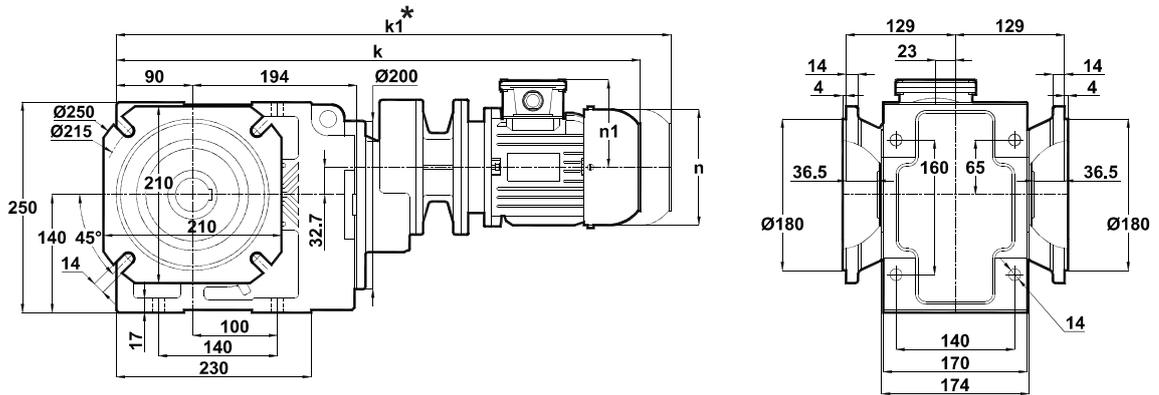

Posizioni morsetteria
Terminal Box Positions
Klemmenkasten Positionen

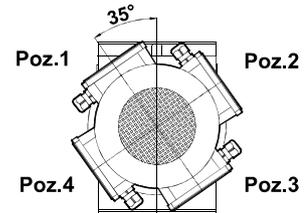

63-71-80
Tipo / Type / Typ

	63/B5	71/B5	80/B5
k	621	618	667
k1	-	738	787
n	116	138	156
n1	97	110	118

La misura "k1" è per motori dotati di freno.
Dimension "k1" is for motors with brake.
Maße "k1" ist für Bremsenmotoren.



Tabelle dimensionali

Dimension Pages

Abmessungsseiten

Foro di centraggio filettato secondo DIN 332 foglio 2 / Tapped center hole to DIN 332, sheet 2 / Zentrierung mit gewinde DIN 332, Blatt 2

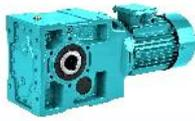
KV375.00
KV376.00

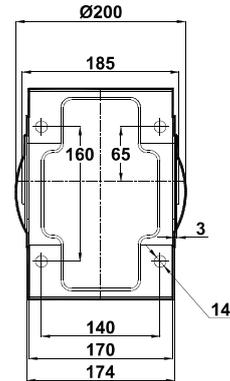
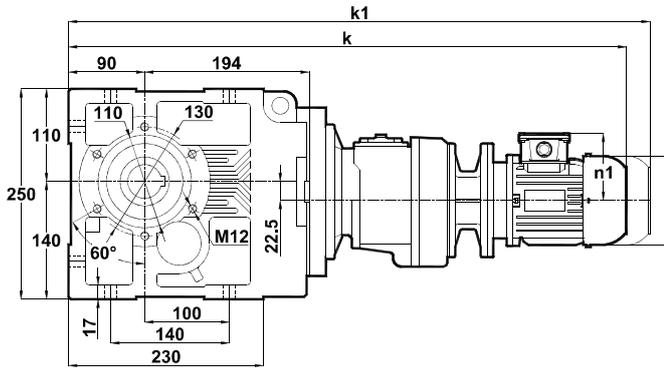

Std.

Ops.

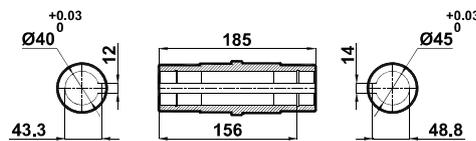

Posizioni morsetteria
Terminal Box Positions
Klemmenkasten Positionen

	63/B5	71/B5
k	688	714
k1	-	834
n	116	138
n1	97	110

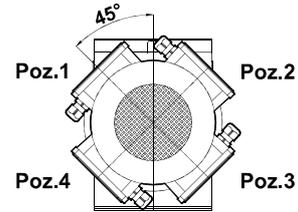

63-71
Tipo / Type / Typ

KV375.01
KV376.01

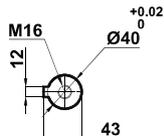
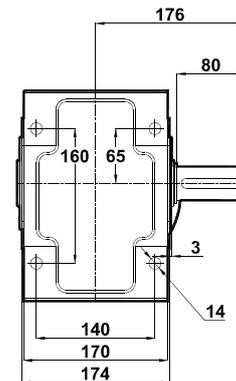
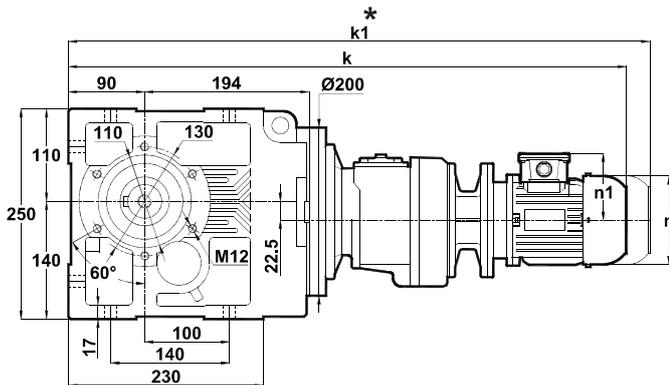

	63/B5	71/B5
k	688	714
k1	-	834
n	116	138
n1	97	110

La misura "k1" è per motori dotati di freno. I riduttori completi di motori elettrici tipo 63 e 71 non hanno la ventola di raffreddamento, che invece hanno gli altri tipi. Dimension "k1" is for motors with brake. Gearboxes with 63 and 71 type electrical motors are not fan cooled, other types are fan cooled.

Maße "k1" ist für Bremsenmotoren. Getrieben mit 63 und 71 typ Motoren sind ohne Kühlung, andere Typen sind mit Ventilator gekühlt.

La misura "k1" è per motori dotati di freno. Dimension "k1" is for motors with brake. Maße "k1" ist für Bremsenmotoren.



Tabella dimensionali

Dimension Pages

Abmessungsseiten

Foro di centraggio filettato secondo DIN 332 foglio 2 / Tapped center hole to DIN 332, sheet 2 / Zentrierung mit gewinde DIN 332, Blatt 2

KV375.02
KV376.02

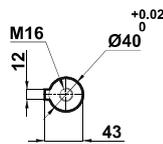
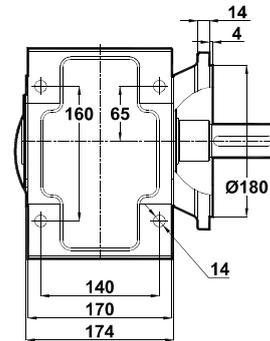
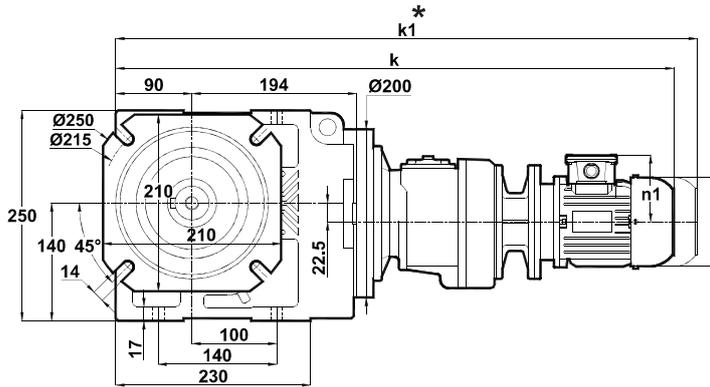

	63/B5	71/B5
k	688	714
k1	-	834
n	116	138
n1	97	110

Posizioni morsettiera
Terminal Box Positions
Klemmenkasten Positionen

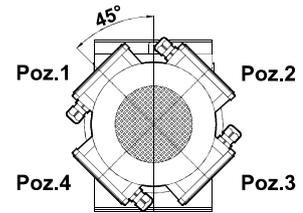

63-71
Tipo / Type / Typ

KV375.03
KV376.03

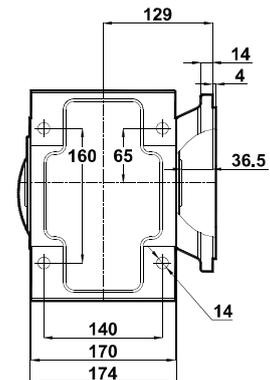
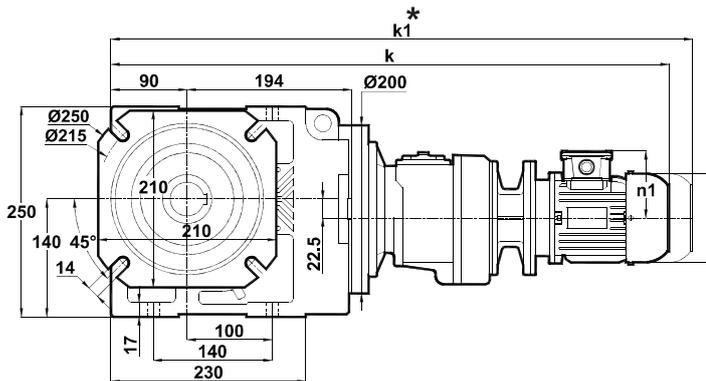

Std.

Ops.

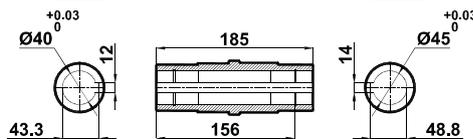

	63/B5	71/B5
k	688	714
k1	-	834
n	116	138
n1	97	110

La misura "k1" è per motori dotati di freno.
Dimension "k1" is for motors with brake.
Maße "k1" ist für Bremsenmotoren.



Tabella dimensionali

Dimension Pages

Abmessungsseiten

Foro di centraggio filettato secondo DIN 332 foglio 2 / Tapped center hole to DIN 332, sheet 2 / Zentrierung mit gewinde DIN 332, Blatt 2

KV375.04
KV376.04

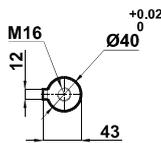
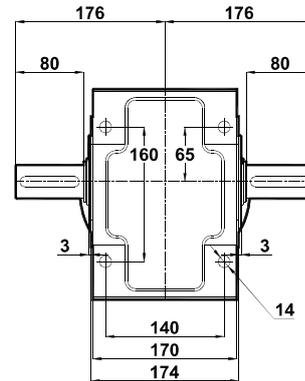
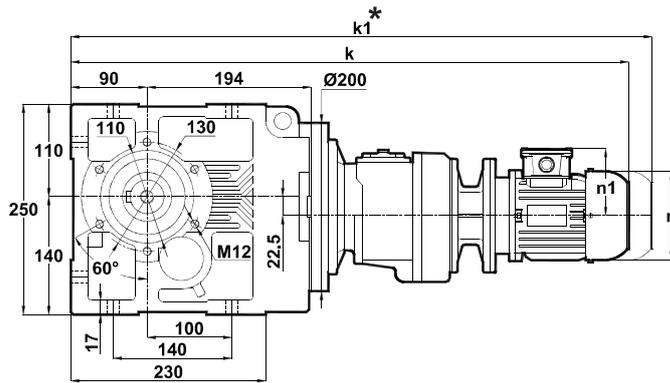

	63/B5	71/B5
k	688	714
k1	-	834
n	116	138
n1	97	110

Posizioni morsettiera
Terminal Box Positions
Klemmenkasten Positionen

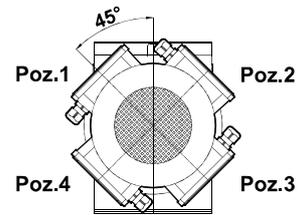

63-71
Tipo / Type / Typ

KV375.05
KV376.05

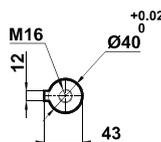
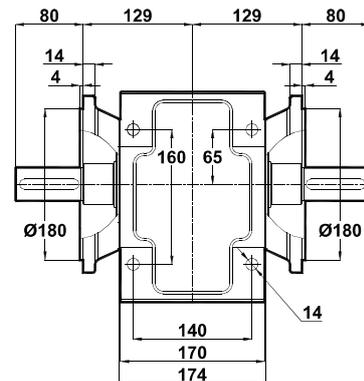
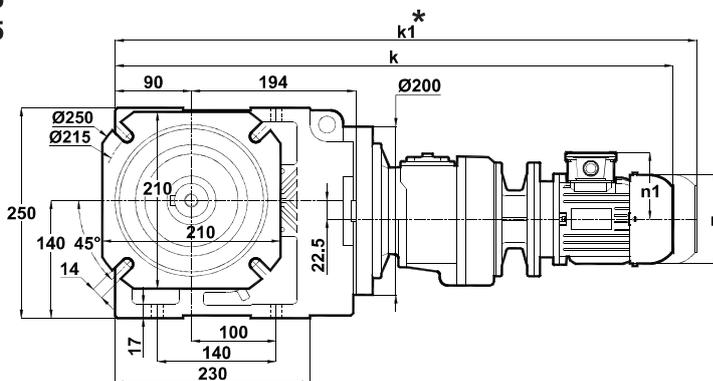

	63/B5	71/B5
k	688	714
k1	-	834
n	116	138
n1	97	110

La misura "k1" è per motori dotati di freno. I riduttori completi di motori elettrici tipo 63 e 71 non hanno la ventola di raffreddamento, che invece hanno gli altri tipi.
Dimension "k1" is for motors with brake. Gearboxes with 63 and 71 type electrical motors are not fan cooled, other types are fan cooled.

Maße "k1" ist für Bremsenmotoren. Getrieben mit 63 und 71 typ Motoren sind ohne Kühlung, andere Typen sind mit Ventilator gekühlt.

La misura "k1" è per motori dotati di freno.
Dimension "k1" is for motors with brake.
Maße "k1" ist für Bremsenmotoren.



Tabella dimensionali

Dimension Pages

Abmessungsseiten

Foro di centraggio filettato secondo DIN 332 foglio 2 / Tapped center hole to DIN 332, sheet 2 / Zentrierung mit gewinde DIN 332, Blatt 2

KV375.08
KV376.08

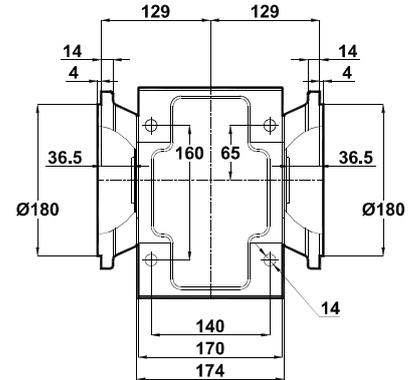
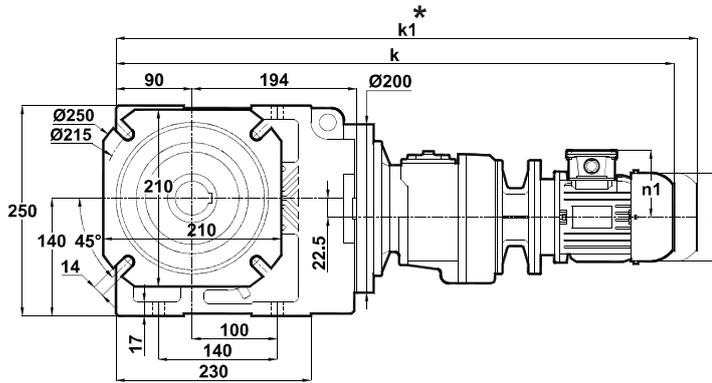

Std.

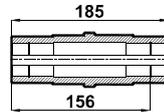
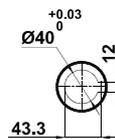

Ops.

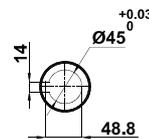

	63/B5	71/B5
k	688	714
k1	-	834
n	116	138
n1	97	110

Posizioni morsettiera
Terminal Box Positions
Klemmenkasten Positionen

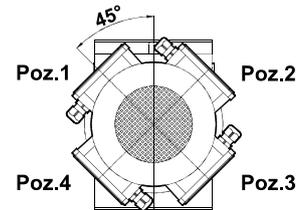

63-71
Tipo / Type / Typ

La misura "k1" è per motori dotati di freno.
Dimension "k1" is for motors with brake.
Maße "k1" ist für Bremsenmotoren.