

CTU3500.1

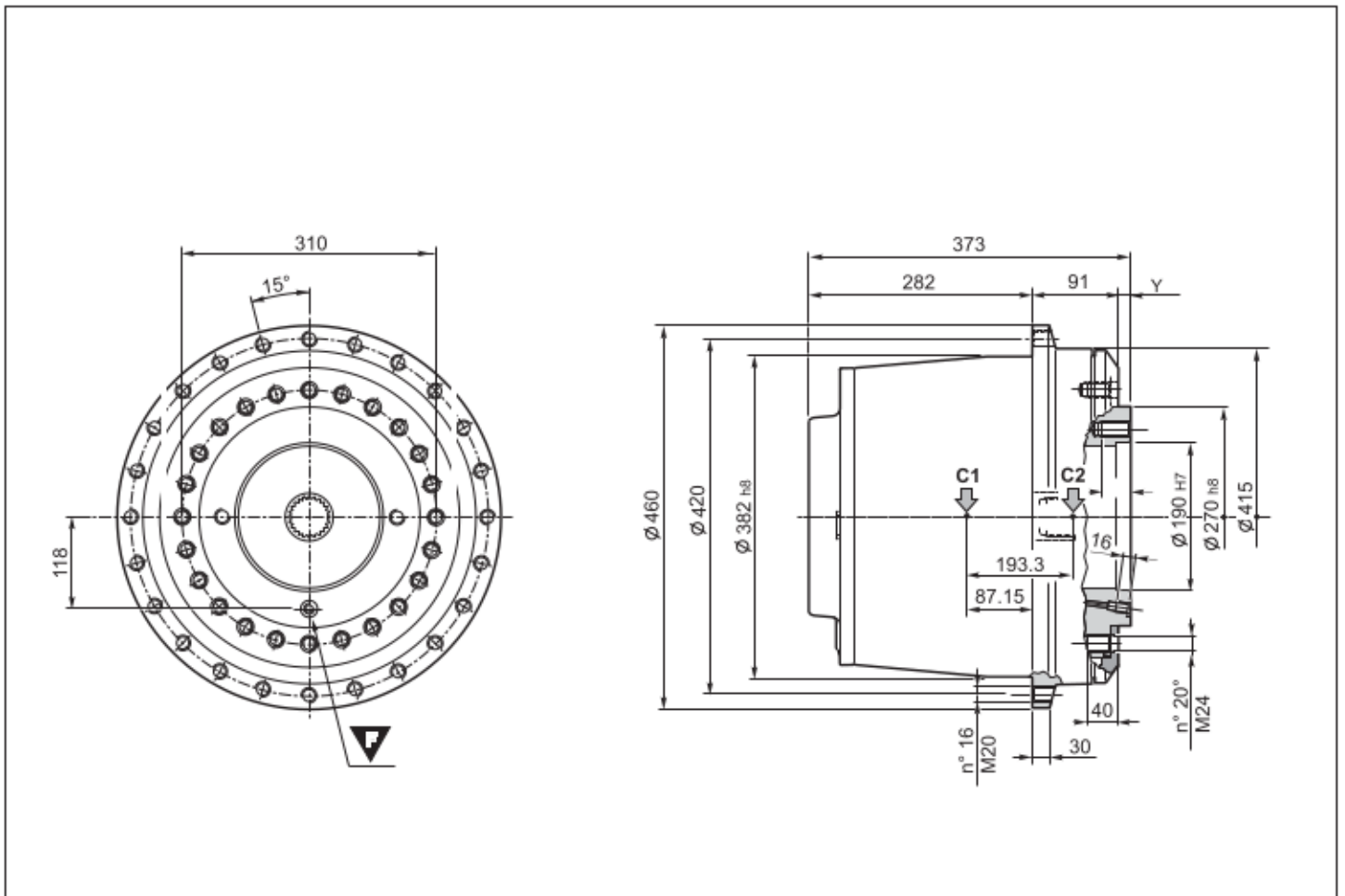

Dati tecnici / Specifications / Technische Daten
Caractéristiques techniques / Datos técnicos / Características técnicas

Tipo / Type / Typ / Type / Tipo / Tipo	T _{2 max.} [Nm]	n _{1 max.} [rpm]	C1 = C2 [KN]	i = (* non disinseribile / no disengage / nicht ausschaltbar / non débrabotables / sin embrague / não desengatáveis)			
CTU3500.1	45.000	3500	248	87,2° - 95,3° - 105,8° - 119,9° - 139,5° - 169°	M12 x 1,5	205	4

Freno Lamellare / Multidisc Brake / Lamellenbremse / Frein à lamelles / Freno de láminas / Freio lamelar

Pa BP [bar]	Pmax BP [bar]	Pa AP [bar]	Pmax AP [bar]	Tf max [Nm]			
-	-	10 + 13	300	300 + 495			
Type	Connection	X	Y	Type	Connection	X	Y
Samhydraulik H1CR90 -Z	Integrated	-	15				
Hydromatik A2FE90 - A	Integrated	-	15				
Hydromatik A6VE80 - A	Integrated	-	15				
Volvo F12 - 80	Integrated	-	15				