

SEQUENCE VALVES - DIRECTLY OPERATED

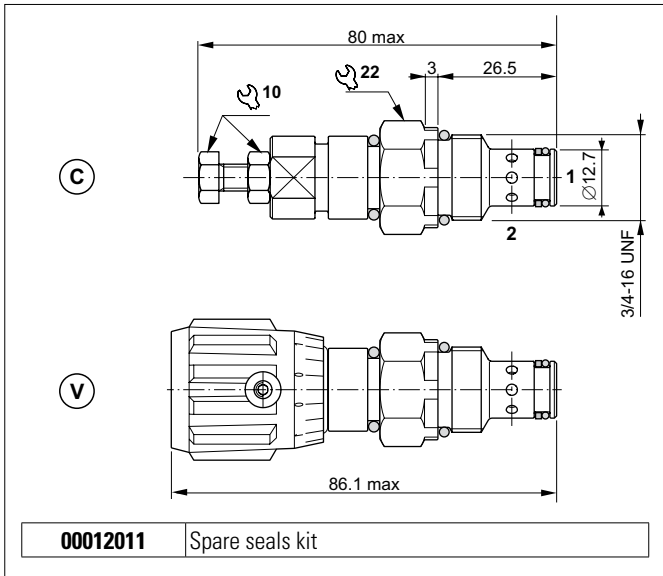

The direct acting sequence valve feeds a secondary branch of a circuit when a set pressure value is reached and suppresses the primary pressure. It raises the safety level by making it impossible for the plant operators to set a higher pressure rating, than that specified in the catalogue. It has a pack spring with a mechanical stop (only standard screw and nut). It has a galvanised steel body. The guided ball poppet is in tempered and ground steel.

HYDRAULIC SYMBOL

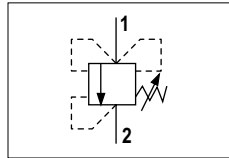

PRESSURE-FLOW RATE

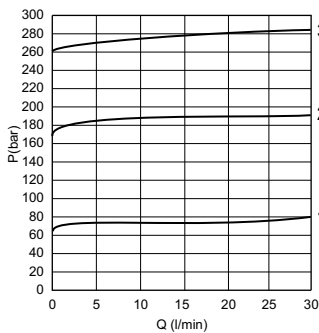

MIN.SETTING PRESSURE

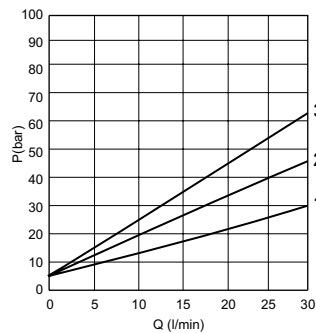

1 = CSQ04.1.. - 2 = CSQ04.2.. - 3 = CSQ04.3..

Fluid used: mineral based oil with viscosity 32 mm²/s at 40°C.

HYDRAULIC FEATURES

Max. opening pressure	350 bar
Setting range:	
Spring 1 (white)	max 70 bar
Spring 2 (yellow)	max 180 bar
Spring 3 (green)	max 340 bar
Max. Flow	30 l/min
Hydraulic fluid	DIN 51524 Mineral oils
Fluid viscosity	10 ÷ 500 mm ² /s
Fluid temperature	-25°C ÷ 75°C
Ambient temperature	-25°C ÷ 60°C
Max. contamin. level class with filter	ISO 4406:1999 - class 19/17/14
Weight	CSQ04C: 0.115 kg CSQ04V: 0.150 kg
Tightening torque	25 ÷ 30 Nm
Cavity (3/4 - 16 UNF)	CD018006 (See section 15)

The minimum permissible setting pressure depending on the spring: see curves below

ORDERING CODE

