

# AM.5.VM... / AM.5.VI... MODULAR MAX. PRESSURE VALVES CETOP 5

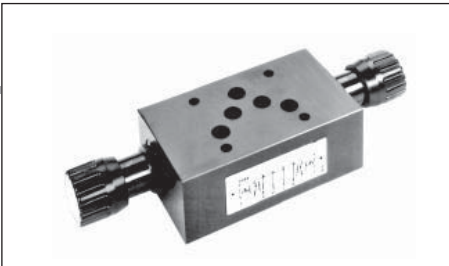

<b>AM.5.VM... / AM.5.VI...</b>	
CMP.20...	BFP CARTRIDGE CATALOGUE
CMP.30...	BFP CARTRIDGE CATALOGUE
SCREWS AND STUDS	CH. IV PAGE 36

AM.5.VM type pressure regulating valves are available within operating range 7 ÷ 350 bar. Adjustment is by means of a grub screw or a plastic knob. They are three basic versions:

**AM.5.VM**, on single A or B lines, and on double A and B lines, with drainage on T; **AM.5.VM.P**, on single P line, with drainage on T; **AM.5.VI**, on single A or B lines, and on double A and B lines, with crossed drainage on either A or B (see hydraulic symbols). Three spring types can be fitted on all versions, with calibrated ranges as shown in the unit specifications.

Piloted operation cartridge type CMP.30 is used on versions AM.5.VM and AM.5.VM.P (see ordering code), while on version AM.5.VI direct acting cartridge type CMP.20 is used instead.

**For the minimum permissible setting pressure depending on the spring, see the minimum pressure setting curve.**

Max. operating pressure	350 bar
Setting ranges:	spring 1 50 bar
	spring 2 140 bar
	spring 3 350 bar
Max. flow	80 l/min
Hydraulic fluids	Mineral oils DIN 51524
Fluid viscosity	10 ÷ 500 mm <sup>2</sup> /s
Fluid temperature	-25°C ÷ 75°C
Ambient temperature	-25°C ÷ 60°C
Max. contamination level	class 10 in accordance with NAS 1638 with filter $\beta_{25} \geq 75$
Weight AM.5.VM.A/B/P...	2,5 Kg
Weight AM.5.VM.AB...	2,7 Kg
Weight AM.5.VI.A/B...	5,7 Kg
Weight AM.5.VI.AB...	5,9 Kg

4

## ORDERING CODE

- AM** Modular valve
- 5** CETOP 5/NG10
- \*\*** **VM** = Maximum pressure  
**VI** = Maximum crossline relief
- \*\*** Adjustment on the lines  
AM.5.VM Version = **A / B / P / AB**  
AM.5.VI Version = **A / B / AB**
- \*** Type of adjustment  
**M** = Plastic knob  
**C** = Grub screw
- \*** Setting ranges at port A/B/P  
CMP 30                  CMP 20  
(AM.5.VM only)      (AM.5.VI only)  
**1** = max. 50 bar    **1** = max.50 bar    (**white spring**)  
**2** = max. 140 bar   **2** = max. 140 bar   (**yellow spring**)  
**3** = max. 350 bar   **3** = max. 250 bar   (**green spring**)
- \*** Setting ranges at port B  
Omit if the setting is same as that at port A  
CMP 30                  CMP 20  
(AM.5.VM only)      (AM.5.VI only)  
**1** = max.50 bar    **1** = max.50 bar    (**white spring**)  
**2** = max. 140 bar   **2** = max. 140 bar   (**yellow spring**)  
**3** = max. 350 bar   **3** = max. 250 bar   (**green spring**)
- \*\*** **00** = No variant  
**V1** = Viton
- 3** Serial No.

## HYDRAULIC SYMBOLS

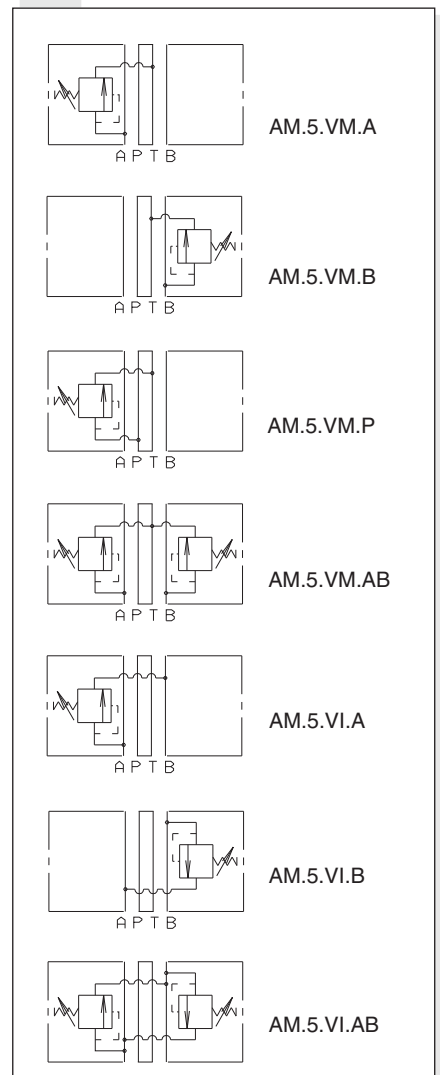

**PRESSURE - FLOW RATE  
FOR CMP.30**

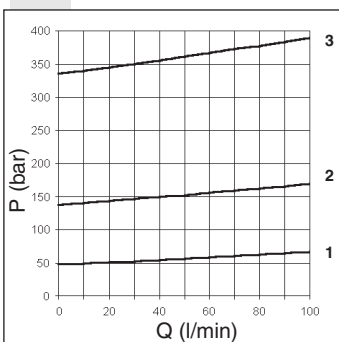

**MINIMUM SETTING PRESSURE  
FOR CMP.30**

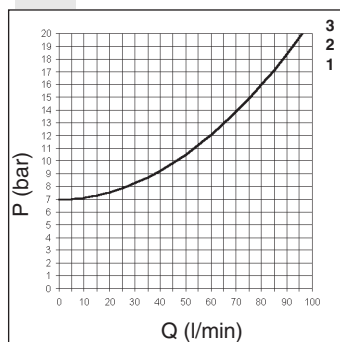

OVERALL DIMENSIONS

AM.5.VM.AB...

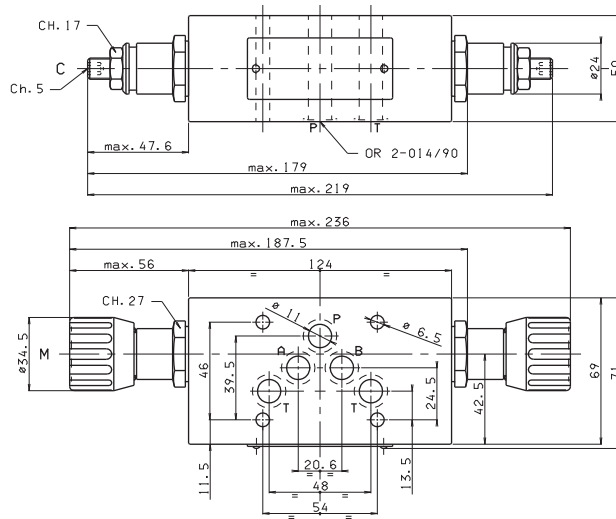

Type of adjustment

- M Plastic knob
- C Grub screw

Support plane specifications

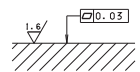

4

AM.5.VM.P...

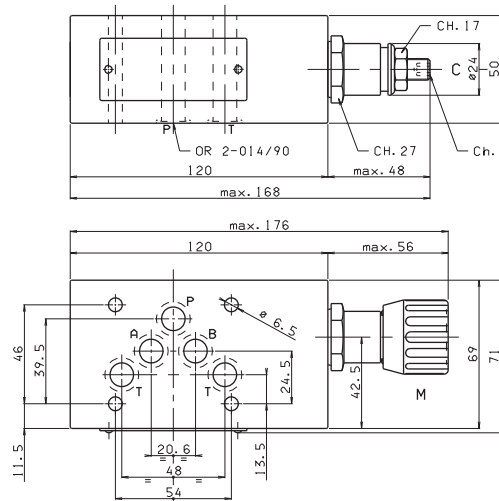

Type of adjustment

- M Plastic knob
- C Grub screw

Support plane specifications

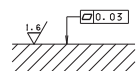

AM.5.VI.AB...

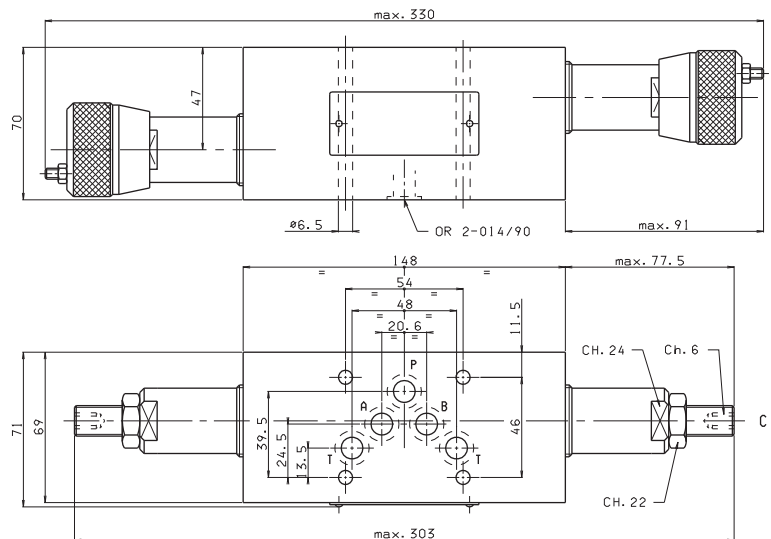

Type of adjustment

- M Plastic knob
- C Grub screw

Support plane specifications

