

AM.3.UP... / AM.3.UP1... MODULAR PILOT OPERATED CHECK VALVES CETOP 3



AM.3.UP / AM.3.UP1...

SCREWS AND STUDS

CH. IV PAGE 21

AM.3.UP type modular check valves allow free flow in one direction by raising a conical seated poppet valve, while in the opposite direction the fluid can return by means of a small piston piloted by the other line pressure (piloted side).

They are available on single A or B lines, and double A and B lines (see hydraulic symbols).

A pre-opening version is also available (AM3UP1..) only with 5 bar spring.

Max. operating pressure	350 bar
Minimum opening pressure spring 1	1 bar
Minimum opening pressure spring 5	5 bar
Piloting ratio AM.3.UP	1:4
Piloting ratio AM.3.UP1	1:12,5
Max. flow	40 l/min
Hydraulic fluids	Mineral oils DIN 51524
Fluid viscosity	10 ÷ 500 mm ² /s
Fluid temperature	-25°C ÷ 75°C
Ambient temperature	-25°C ÷ 60°C
Max. contamination level	class 10 in accordance with NAS 1638 with filter $\beta_{25} \geq 75$
Weight	1 Kg

HYDRAULIC SYMBOLS

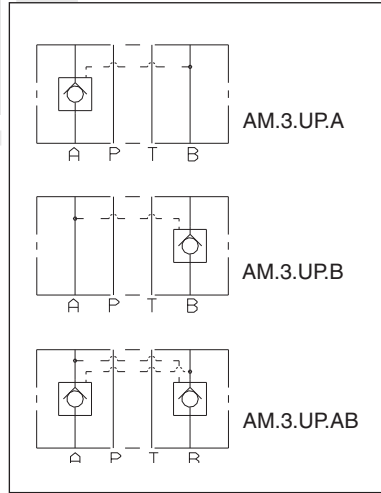

PRESSURE DROPS AM3UP

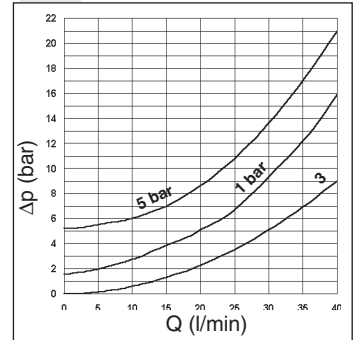

PRESSURE DROPS AM3UP1

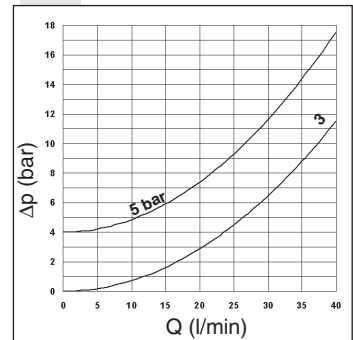

Curve n. 3 = Piloted side flow

ORDERING CODE

- AM** Modular valve
- 3** CETOP 3/NG6
- **** **UP** = Piloted check valve
UP1 = With pre-opening
- **** Control on lines **A / B / AB**
- *** Minimum opening pressure
1 = 1 bar (only for UP version)
5 = 5 bar
8 = 8 bar (only for UP version)
- **** **00** = No variant
V1 = Viton
- 3** Serial No.

The fluid used is a mineral oil with a viscosity of 46 mm²/s at 40°C. The tests have been carried out at a fluid temperature of 50°C.

OVERALL DIMENSIONS

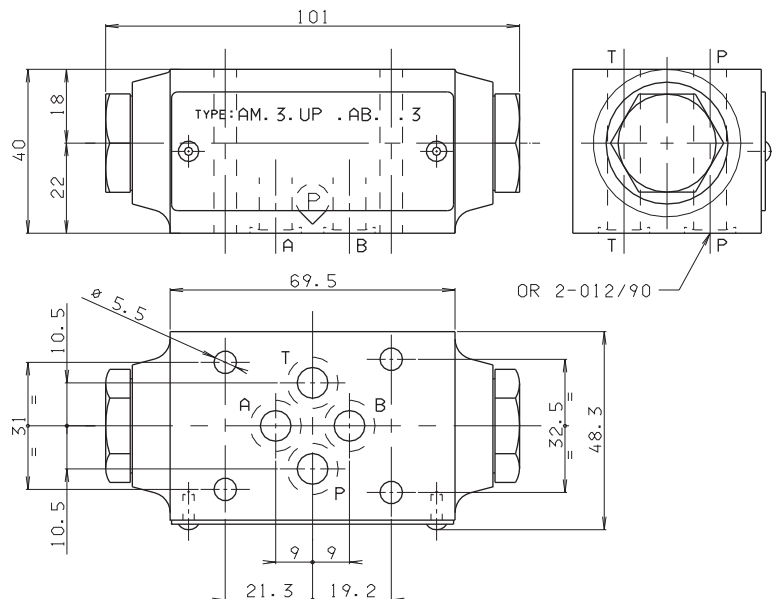

Support plane specifications

