

AM.3.RD... / AM.3.SD... MODULAR PRESSURE REDUCING / PRESSURE SEQUENCING VALVES CETOP 3



AM.3.RD / AM.3.SD...
SCREWS AND STUDS CH. IV PAGE 21

AM3RD and AM3SD valves are direct acting spool type pressure reducing and sequencing units, respectively, with one end pre-loaded by means of a spring at the other end exposed to the hydraulic pressure.

The drainage is drained within the valve to port T. Pressure is adjustable by means of a screw and locknut, or of a handwheel. Three types of springs allow adjustment within the range 2÷250 bar. The pressure reducing valves are available in two versions: with positive overlap (suitable with low flow rate) and with negative overlap to obtain a greater pressure reinstatement speed.

Max. operating pressure: port P	350 bar
Max. pressure adjustable	250 bar
Setting ranges:	
spring 1	2 ÷ 30 bar
spring 2	10 ÷ 120 bar
spring 3	60 ÷ 250 bar
Max. flow	40 l/min
Internal drainage RD:	
Positive overlap version	0,5 l/min
Negative overlap version	2 l/min
Hydraulic fluids	Mineral oils DIN 51524
Fluid viscosity	10 ÷ 500 mm ² /s
Fluid temperature	-25°C ÷ 75°C
Ambient temperature	-25°C ÷ 60°C
Max. contamination level	class 10 in accordance with NAS 1638 with filter $\beta_{25} \geq 75$
Weight	1,3 Kg

ORDERING CODE

- AM** Modular valve
- 3** CETOP 3/NG6
- **** **RD** = Direct pressure reducing valve
SD = Direct pressure sequencing valve
- *** Control on lines
AM.3.RD version = **A / P**
AM.3.SD version = **P**
- *** **1** = Positive overlap
2 = Negative overlap
Omit for version AM3SD
- *** Type of adjustment
C = Grub screw
V = Handwheel
- *** Setting ranges
1 = max. 2 ÷ 30 bar (**white spring**)
2 = max. 10 ÷ 120 bar (**yellow spring**)
3 = max. 60 ÷ 250 bar (**green spring**)
- **** **00** = No variant
V1 = Viton
- 4** Serial No.

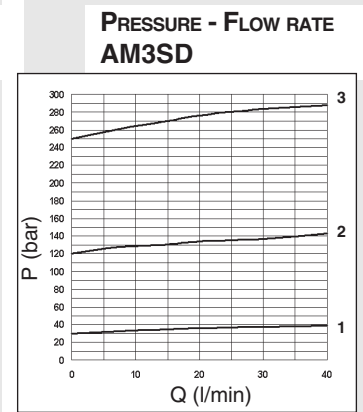
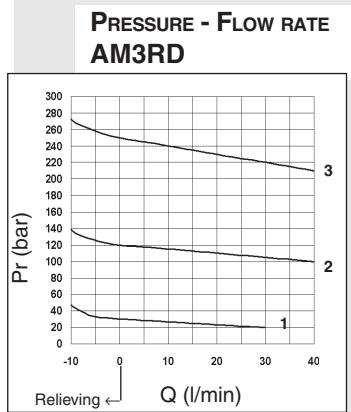

The fluid used is a mineral based oil with a viscosity of 46 mm²/sec at 40 degrees C. The tests have been carried out at with a fluid temperature of 40 degrees C.

OVERALL DIMENSIONS

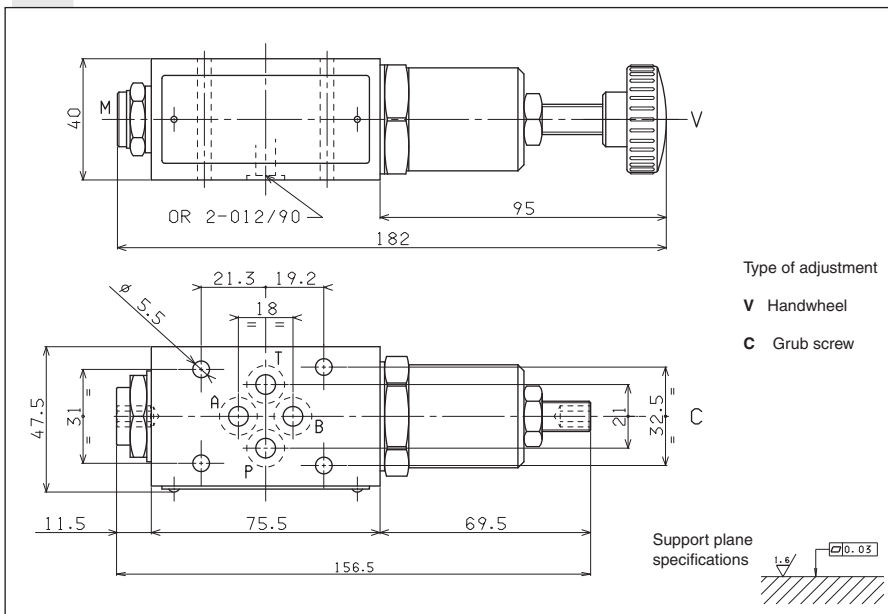

HYDRAULIC SYMBOLS

