

AM.3.CP... MODULAR BACK PRESSURE VALVE CETOP 3



AM.3.CP...	
CMP.10...	BFP CARTRIDGE CATALOGUE
SCREWS AND STUDS	CH. IV PAGE 21

AM3CP type back pressure valves are damped in-line direct acting pressure relief valves fitted with bypass non-return valves.

Adjustment within the range 2 ÷ 320 bar is by means of a grub screw or a plastic knob, on ports A or B (single) or AB (double).

The cartridge is the direct acting type CMP10.

These valves are especially used on vertically working cylinders with dragging loads.

Max. operating pressure	350 bar	
Setting ranges:	spring 1	max. 50 bar
	spring 2	max. 150 bar
	spring 3	max. 320 bar
Max. flow	40 l/min	
Hydraulic fluids	Mineral oils DIN 51524	
Fluid viscosity	10 ÷ 500 mm ² /s	
Fluid temperature	-25°C ÷ 75°C	
Ambient temperature	-25°C ÷ 60°C	
Max. contamination level	class 10 in accordance with NAS 1638 with filter $\beta_{25} \geq 75$	
Weight AM.3.CP.A/B...	2 Kg	
Weight AM.3.CP.AB...	2,7 Kg	

For the minimum permissible setting pressure depending on the spring, see minimum pressure setting curve.

ORDERING CODE

AM	Modular valve
3	CETOP 3/NG6
CP	Back pressure valve
**	Control on lines A / B / AB
*	Type of adjustment M = Plastic knob C = Grub screw
*	Setting ranges 1 = max. 50 bar (white spring) 2 = max. 150 bar (yellow spring) 3 = max. 320 bar (green spring)
**	00 = No variant V1 = Viton
3	Serial No.

HYDRAULIC SYMBOLS

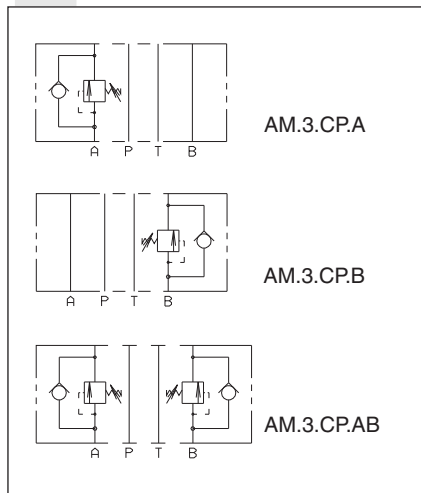

PRESSURE - FLOW RATE

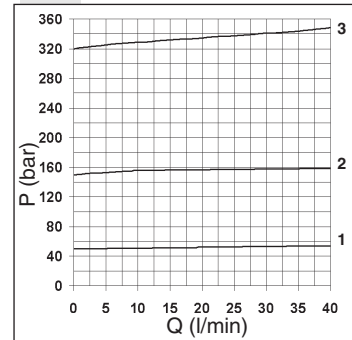

MINIMUM SETTING PRESSURE

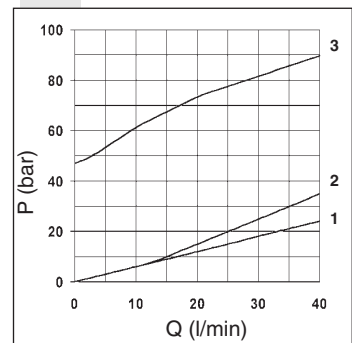

OVERALL DIMENSIONS

